

SECTION **CL**
CLUTCH

A
B
C

CL

CONTENTS

E

| | | | | |
|--|---|--|----|---|
| SYMPTOM DIAGNOSIS | 2 | Removal and Installation | 9 | F |
| NOISE, VIBRATION AND HARSHNESS (NVH) TROUBLESHOOTING | 2 | Inspection and Adjustment | 10 | |
| NVH Troubleshooting Chart | 2 | CLUTCH MASTER CYLINDER | 11 | G |
| PRECAUTION | 3 | Exploded View | 11 | |
| PRECAUTIONS | 3 | Removal and Installation | 11 | |
| Precaution for Supplemental Restraint System (SRS) "AIR BAG" and "SEAT BELT PRE-TENSIONER" | 3 | Disassembly and Assembly | 13 | H |
| Precaution Necessary for Steering Wheel Rotation after Battery Disconnect | 3 | Inspection and Adjustment | 14 | |
| Precaution for Battery Service | 4 | CLUTCH PIPING | 15 | I |
| Precaution for Procedure without Cowl Top Cover..... | 4 | Exploded View | 15 | |
| Service Notice or Precautions for Clutch | 4 | Hydraulic Layout | 15 | |
| PREPARATION | 5 | Removal and Installation | 16 | J |
| PREPARATION | 5 | Inspection and Adjustment | 16 | |
| Special Service Tools | 5 | UNIT REMOVAL AND INSTALLATION | 17 | K |
| Commercial Service Tools | 5 | CSC (CONCENTRIC SLAVE CYLINDER) | 17 | |
| PERIODIC MAINTENANCE | 6 | Exploded View | 17 | L |
| CLUTCH PEDAL | 6 | Removal and Installation | 17 | |
| Inspection and Adjustment | 6 | Inspection and Adjustment | 20 | |
| CLUTCH FLUID | 7 | CLUTCH DISC AND CLUTCH COVER | 21 | M |
| Inspection | 7 | Exploded View | 21 | |
| Draining | 7 | Removal and Installation | 21 | |
| Refilling | 7 | Inspection | 22 | N |
| Air Bleeding Procedure | 7 | SERVICE DATA AND SPECIFICATIONS (SDS) | 24 | |
| REMOVAL AND INSTALLATION | 9 | SERVICE DATA AND SPECIFICATIONS (SDS) | 24 | O |
| CLUTCH PEDAL | 9 | Clutch Control System | 24 | |
| Exploded View | 9 | Clutch Pedal | 24 | P |
| | | Clutch Master Cylinder | 24 | |
| | | Clutch Disc | 24 | |
| | | Clutch Cover | 24 | |

NOISE, VIBRATION AND HARSHNESS (NVH) TROUBLESHOOTING

< SYMPTOM DIAGNOSIS >

SYMPTOM DIAGNOSIS

NOISE, VIBRATION AND HARSHNESS (NVH) TROUBLESHOOTING

NVH Troubleshooting Chart

INFOID:000000005630960

Use the chart below to find the cause of the symptom. The numbers indicate the order of the inspection. If necessary, repair or replace these parts.

| SYMPTOM | | SUSPECTED PARTS (Possible cause) | | | | | | | | | | | | | | | | |
|-----------|---------------------------|--|---------------------------|--------------------------------------|-------------------------|--|---------------------------|-----------------------------------|-----------------------------|-------------------------------|--------------------|------------------------|------------------------|-------------------------------------|----------------------------|---|-----------------------------|------------------------|
| | | CLUTCH PEDAL (Inspection and adjustment) | CLUTCH LINE (Air in line) | MASTER CYLINDER PISTON CUP (Damaged) | ENGINE MOUNTING (Loose) | CSC (Concentric Slave Cylinder) (Worn, dirty or damaged) | CLUTCH DISC (Out of true) | CLUTCH DISC (Runout is excessive) | CLUTCH DISC (Lining broken) | CLUTCH DISC (Dirty or burned) | CLUTCH DISC (Oily) | CLUTCH DISC (Worn out) | CLUTCH DISC (Hardened) | CLUTCH DISC (Lack of spline grease) | DIAPHRAGM SPRING (Damaged) | DIAPHRAGM SPRING (Out of tip alignment) | PRESSURE PLATE (Distortion) | FLYWHEEL (Distortion) |
| Reference | | CL-6 | CL-7 | CL-11 | EM-68 | CL-17 | | | | | | CL-21 | | | | | | EM-121 |
| Symptom | Clutch grabs/chatters | | | | 1 | | | | | | 2 | 2 | 2 | | | | 2 | |
| | Clutch pedal spongy | | 1 | 2 | | 2 | | | | | | | | | | | | |
| | Clutch noisy | | | | | 1 | | | | | | | | | | | | |
| | Clutch slips | 1 | | | | | | | | | 2 | 2 | | | 3 | | 4 | 5 |
| | Clutch does not disengage | 1 | 2 | 3 | | 4 | 4 | 4 | 4 | 4 | 4 | | | 4 | 5 | 5 | 6 | |

PRECAUTIONS

< PRECAUTION >

PRECAUTION

PRECAUTIONS

Precaution for Supplemental Restraint System (SRS) "AIR BAG" and "SEAT BELT PRE-TENSIONER"

INFOID:000000005630961

The Supplemental Restraint System such as "AIR BAG" and "SEAT BELT PRE-TENSIONER", used along with a front seat belt, helps to reduce the risk or severity of injury to the driver and front passenger for certain types of collision. This system includes seat belt switch inputs and dual stage front air bag modules. The SRS system uses the seat belt switches to determine the front air bag deployment, and may only deploy one front air bag, depending on the severity of a collision and whether the front occupants are belted or unbelted. Information necessary to service the system safely is included in the "SRS AIR BAG" and "SEAT BELT" of this Service Manual.

WARNING:

- To avoid rendering the SRS inoperative, which could increase the risk of personal injury or death in the event of a collision which would result in air bag inflation, all maintenance must be performed by an authorized NISSAN/INFINITI dealer.
- Improper maintenance, including incorrect removal and installation of the SRS, can lead to personal injury caused by unintentional activation of the system. For removal of Spiral Cable and Air Bag Module, see the "SRS AIR BAG".
- Do not use electrical test equipment on any circuit related to the SRS unless instructed to in this Service Manual. SRS wiring harnesses can be identified by yellow and/or orange harnesses or harness connectors.

PRECAUTIONS WHEN USING POWER TOOLS (AIR OR ELECTRIC) AND HAMMERS

WARNING:

- When working near the Air Bag Diagnosis Sensor Unit or other Air Bag System sensors with the ignition ON or engine running, DO NOT use air or electric power tools or strike near the sensor(s) with a hammer. Heavy vibration could activate the sensor(s) and deploy the air bag(s), possibly causing serious injury.
- When using air or electric power tools or hammers, always switch the ignition OFF, disconnect the battery, and wait at least 3 minutes before performing any service.

Precaution Necessary for Steering Wheel Rotation after Battery Disconnect

INFOID:000000005630962

NOTE:

- Before removing and installing any control units, first turn the push-button ignition switch to the LOCK position, then disconnect both battery cables.
- After finishing work, confirm that all control unit connectors are connected properly, then re-connect both battery cables.
- Always use CONSULT-III to perform self-diagnosis as a part of each function inspection after finishing work. If a DTC is detected, perform trouble diagnosis according to self-diagnosis results.

For vehicle with steering lock unit, if the battery is disconnected or discharged, the steering wheel will lock and cannot be turned.

If turning the steering wheel is required with the battery disconnected or discharged, follow the operation procedure below before starting the repair operation.

OPERATION PROCEDURE

1. Connect both battery cables.

NOTE:

Supply power using jumper cables if battery is discharged.

2. Turn the push-button ignition switch to ACC position.
(At this time, the steering lock will be released.)
3. Disconnect both battery cables. The steering lock will remain released with both battery cables disconnected and the steering wheel can be turned.
4. Perform the necessary repair operation.

PRECAUTIONS

< PRECAUTION >

5. When the repair work is completed, re-connect both battery cables. With the brake pedal released, turn the push-button ignition switch from ACC position to ON position, then to LOCK position. (The steering wheel will lock when the push-button ignition switch is turned to LOCK position.)
6. Perform self-diagnosis check of all control units using CONSULT-III.

Precaution for Battery Service

INFOID:000000005630963

Before disconnecting the battery, lower both the driver and passenger windows. This will prevent any interference between the window edge and the vehicle when the door is opened/closed. During normal operation, the window slightly raises and lowers automatically to prevent any window to vehicle interference. The automatic window function will not work with the battery disconnected.

Precaution for Procedure without Cowl Top Cover

INFOID:000000005630964

When performing the procedure after removing cowl top cover, cover the lower end of windshield with urethane, etc.

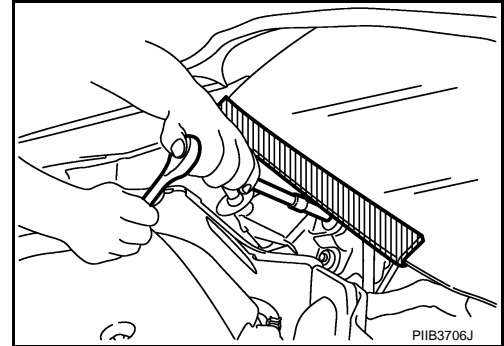

Service Notice or Precautions for Clutch

INFOID:000000005630965

WARNING:

After cleaning clutch disc, wipe it with a dust collector. Never use compressed air.

CAUTION:

- Clutch fluid use refer to [MA-10, "Fluids and Lubricants"](#).
- Never reuse drained clutch fluid.
- Keep painted surface on the body or other parts free of clutch fluid. If it spills, wipe up immediately and wash the affected area with water.
- When removing clutch tube, use a flare nut wrench.
- When installing clutch tube, use a flare nut torque wrench [Commercial service tool].
- Use new clutch fluid to clean or wash all parts of master cylinder.
- Never use mineral oils such as gasoline or kerosene. It will ruin the rubber parts of the hydraulic system.
- Never reuse CSC (Concentric Slave Cylinder) body and CSC tube. Because CSC slides back to the original position every time when removing transmission assembly. At this timing, dust on the sliding parts may damage a seal of CSC and may cause clutch fluid leakage. Refer to [CL-17, "Removal and Installation"](#).
- Never disassemble CSC body.

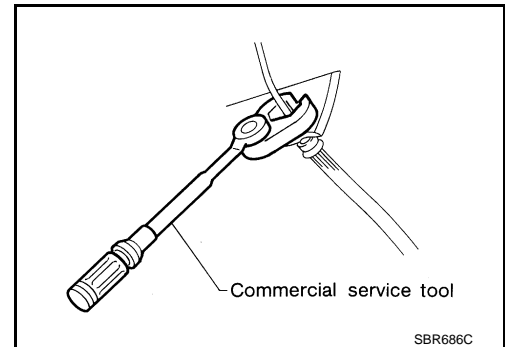

PREPARATION

< PREPARATION >

PREPARATION

PREPARATION

Special Service Tools

INFOID:0000000005630966

The actual shapes of Kent-Moore tools may differ from those of special service tools illustrated here.

| Tool number (Kent-Moore No.) Tool name | Description |
|--|--|
| ST20050240 (-) Diaphragm adjusting wrench  ZZA0508D | Adjusting unevenness of diaphragm spring lever |

Commercial Service Tools

INFOID:0000000005630967

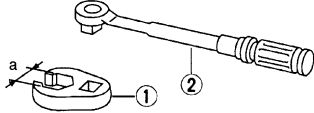
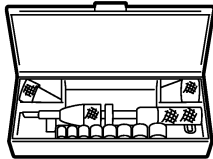
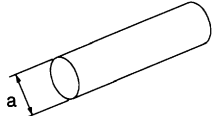
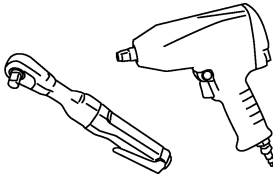
| Tool name | Description |
|---|--------------------------|
| Flare nut torque wrench 1. Flare nut crowfoot a: 10 mm (0.39 in) 2. Torque wrench  S-NT360 | Installing clutch tube |
| Clutch aligner  MCIB0404E | Installing clutch disc |
| Drift a: 10 mm (0.39 in) dia.  S-NT063 | Removing bushing |
| Power tool  PBIC0190E | Loosening bolts and nuts |

CLUTCH PEDAL

< PERIODIC MAINTENANCE >

PERIODIC MAINTENANCE

CLUTCH PEDAL

Inspection and Adjustment

INFOID:000000005630968

INSPECTION

1. Make sure that clevis pin (1) floats freely in the bore of clutch pedal. It should not be bound by clevis or clutch pedal.
 - a. If clevis pin is not free, make sure that ASCD clutch switch (2) is not applying pressure to clutch pedal causing clevis pin to bind. To adjust, loosen lock nut (3) and turn ASCD clutch switch.
 - b. Tighten lock nut. Refer to [CL-9, "Exploded View"](#).
 - c. Make sure that clevis pin floats in the bore of clutch pedal. It should not be bound by clutch pedal.
 - d. If clevis pin is still not free, remove clevis pin and check for deformation or damage. Replace clevis pin if necessary. Leave clevis pin removed for step 2.
2. Check clutch pedal stroke for free range of movement.
 - a. With clevis pin removed, manually move clutch pedal up and down to determine if it moves freely.
 - b. If any sticking is found, replace related parts (bushing, clutch pedal, etc.). Reassemble clutch pedal and again make sure that clevis pin floats freely in the bore of clutch pedal.
3. Check clutch hydraulic and system components (clutch master cylinder, CSC, etc.) for sticking or binding.
 - a. If any sticking or binding is found, repair or replace related parts as necessary.
 - b. If hydraulic system repair was necessary, bleed the clutch hydraulic system. Refer to [CL-7, "Air Bleeding Procedure"](#).

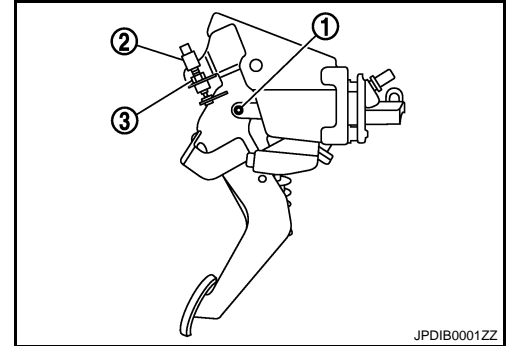

NOTE:

Do not use a vacuum assist or any other type of power bleeder on this system. Use of vacuum assist or power bleeder will not purge all the air from the system.

ADJUSTMENT

1. Adjust clutch interlock switch (1) position so that clearance between stopper rubber (2) and thread end (A) of clutch interlock switch with clutch pedal depressed is clearance "C".

Clearance "C" : Refer to [CL-24, "Clutch Pedal"](#).
2. After adjusting clearance "C", tighten lock nut (3) to the specified torque. Refer to [CL-9, "Exploded View"](#).

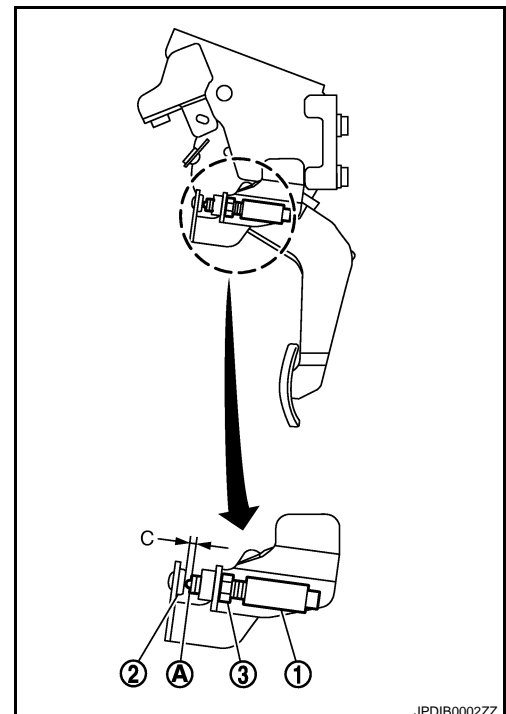

CLUTCH FLUID

< PERIODIC MAINTENANCE >

CLUTCH FLUID

Inspection

INFOID:000000005630969

FLUID LEAKAGE

- Check clutch line (tubes and hoses) for cracks, deterioration or other damage. Replace any damaged parts.
- Check for fluid leakage by fully depressing clutch pedal while engine is running.

CAUTION:

If leakage occurs around joints, retighten or, if necessary, replace damaged parts.

FLUID LEVEL

- Check that the fluid level in the reservoir tank is within the specified range (MAX – MIN lines).
- Visually check for any fluid leakage around the reservoir tank.
- Check the clutch system for any leakage if the fluid level is extremely low (lower than MIN).

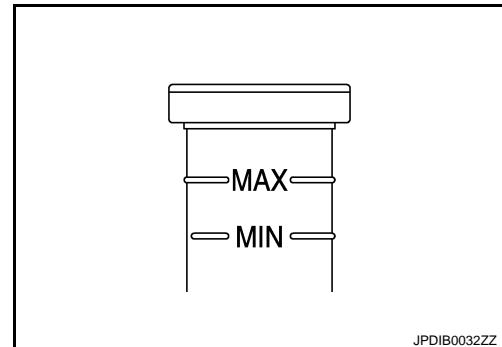

Draining

INFOID:000000005630970

CAUTION:

Keep painted surface on the body or other parts free of clutch fluid. If it spills, wipe up immediately and wash the affected area with water.

1. Connect a transparent vinyl hose to air bleeder valve.
2. Depress clutch pedal and loosen air bleeder valve to gradually discharge clutch fluid.

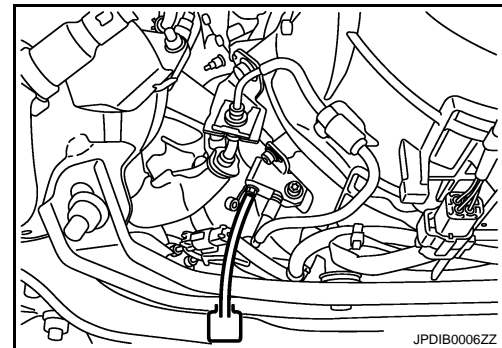

Refilling

INFOID:000000005630971

CAUTION:

Keep painted surface on the body or other parts free of clutch fluid. If it spills, wipe up immediately and wash the affected area with water.

1. Check that there is no foreign material in reservoir tank and then fill with new clutch fluid.

CAUTION:

Never reuse drained clutch fluid.

2. Loosen air bleeder valve, slowly depress clutch pedal to the full stroke and then release clutch pedal.
3. Repeat this operation at intervals of 2 or 3 seconds until new clutch fluid is discharged.
4. Tighten air bleeder valve with the clutch pedal depressed.
5. Perform the air bleeding. Refer to [CL-7, "Air Bleeding Procedure"](#).

Air Bleeding Procedure

INFOID:000000005630972

CAUTION:

- Monitor clutch fluid level in reservoir tank to make sure it does not empty.
- Keep painted surface on the body or other parts free of clutch fluid. If it spills, wipe up immediately and wash the affected area with water.

CLUTCH FLUID

< PERIODIC MAINTENANCE >

NOTE:

Do not use a vacuum assist or any other type of power bleeder on this system. Use of vacuum assist or power bleeder will not purge all the air from the system.

1. Fill master cylinder reservoir tank with new clutch fluid.

CAUTION:

Never reuse drained clutch fluid.

2. Connect a transparent vinyl hose to air bleeder valve.
3. Depress clutch pedal slowly and fully several times at an interval of 2 to 3 seconds and hold it.
4. With clutch pedal depressed, loosen air bleeder valve to release air.
5. Tighten air bleeder valve.
6. Release clutch pedal and wait for 5 seconds.
7. Repeat steps 3 to 6 until no bubbles can be observed in clutch fluid.
8. Tighten air bleeder valve to the specified torque. Refer to [CL-17. "Exploded View"](#).
9. Check that the fluid level in the reservoir tank is within the specified range after air bleeding. Refer to [CL-7. "Inspection"](#).

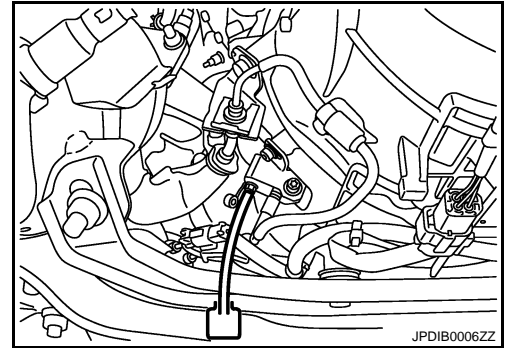

CLUTCH PEDAL

< REMOVAL AND INSTALLATION >

REMOVAL AND INSTALLATION

CLUTCH PEDAL

Exploded View

INFOID:000000005630973

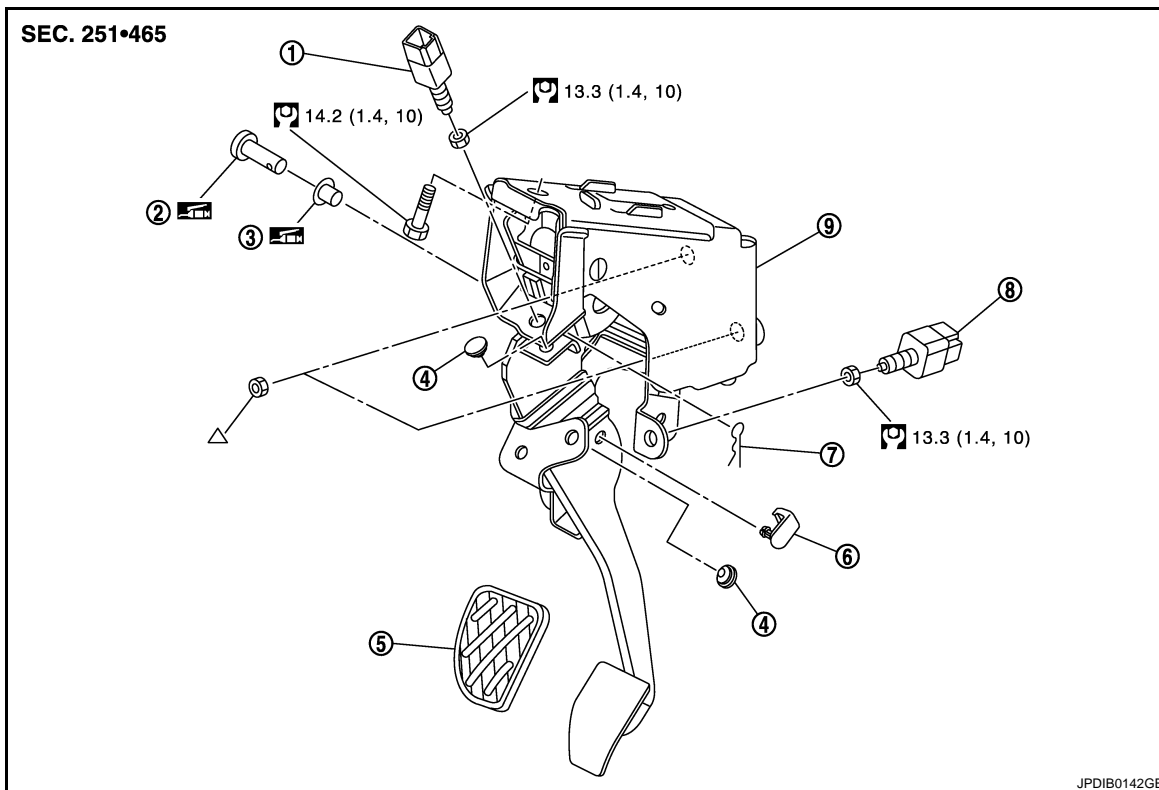

- | | | |
|-----------------------|----------------------------|-------------------------|
| 1. ASCD clutch switch | 2. Clevis pin | 3. Bushing |
| 4. Stopper rubber | 5. Pedal pad | 6. Pedal stopper rubber |
| 7. Snap pin | 8. Clutch interlock switch | 9. Clutch pedal |

: Apply lithium-based grease including molybdenum disulphide.

△: Refer to [CL-11, "Exploded View"](#) for the tightening torque.

Refer to [GI-4, "Components"](#) for symbols not described on the above.

Removal and Installation

INFOID:000000005630974

REMOVAL

1. Remove kicking plate inner and dash side finisher. Refer to [INT-15, "Removal and Installation"](#).
2. Remove instrument lower panel LH. Refer to [IP-23, "M/T MODELS : Removal and Installation"](#).
3. Remove bracket (1) and harness bracket (2).
4. Disconnect ASCD clutch switch and clutch interlock switch connectors and then remove clip of harness from clutch pedal.
5. Remove snap pin and clevis pin from clevis.
6. Remove ASCD clutch switch, clutch interlock switch, and pedal pad from clutch pedal.
7. Remove stopper rubbers and pedal stopper rubber from clutch pedal, using a suitable remover.
8. Remove clutch pedal from the vehicle.
9. Remove bushing from clutch pedal, using a suitable drift [Commercial service tool].

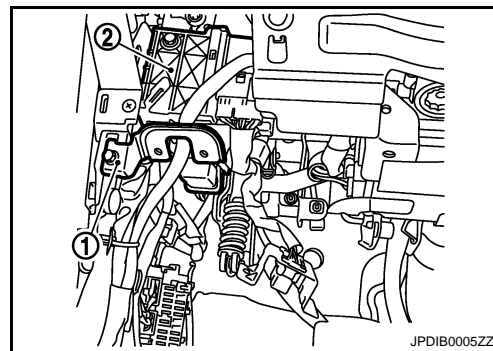

CLUTCH PEDAL

< REMOVAL AND INSTALLATION >

INSTALLATION

Note the following, and install in the reverse order of removal.

- Apply recommended grease to bushing.
- Apply recommended grease to clevis pin.

Inspection and Adjustment

INFOID:000000005630975

INSPECTION AFTER REMOVAL

Check the following items and replace clutch pedal if necessary.

- Check clutch pedal upper rivets (A) for deformation.

⇐ : Vehicle front

- Check the lapping length "L" of sub-bracket (B) and slide plate (C).

Lapping length "L" : More than 5 mm (0.20 in)

- Check clutch pedal for bend, damage, and cracks on the welded parts.

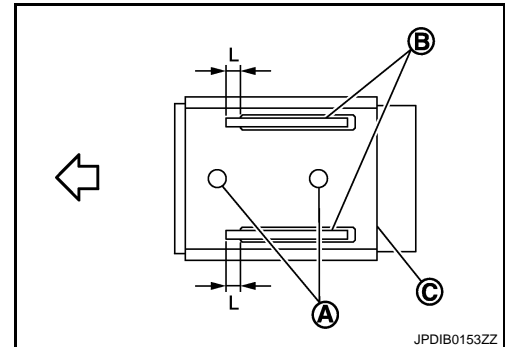

INSPECTION AFTER INSTALLATION

Check the clutch pedal free play. Refer to [CL-6, "Inspection and Adjustment"](#).

ADJUSTMENT AFTER INSTALLATION

Adjust the clutch interlock switch position. Refer to [CL-6, "Inspection and Adjustment"](#).

CLUTCH MASTER CYLINDER

< REMOVAL AND INSTALLATION >

CLUTCH MASTER CYLINDER

Exploded View

INFOID:000000005630976

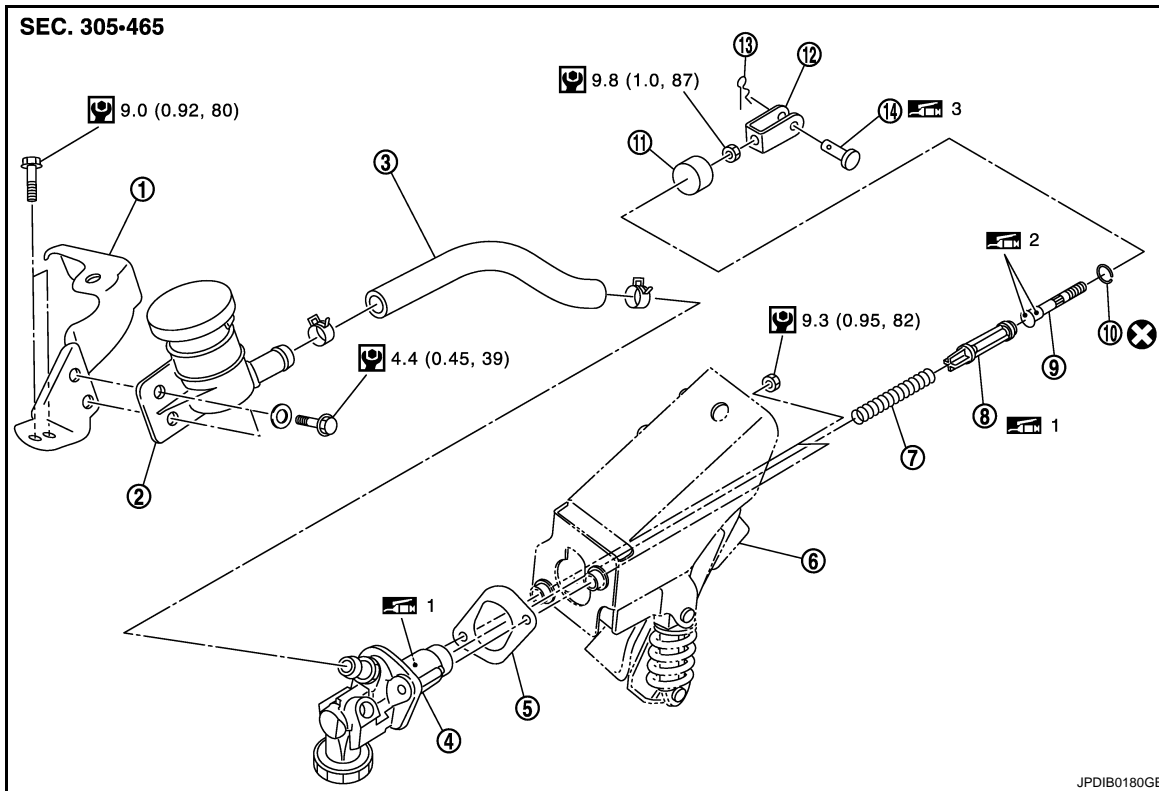

- | | | |
|--------------------|-------------------|-----------------|
| 1. Bracket | 2. Reservoir tank | 3. Hose |
| 4. Master cylinder | 5. Packing | 6. Clutch pedal |
| 7. Return spring | 8. Piston | 9. Push rod |
| 10. Stopper ring | 11. Boot | 12. Clevis |
| 13. Snap pin | 14. Clevis pin | |

 1: Apply rubber lubricant.

 2: Apply silicone grease.

 3: Apply lithium-based grease including molybdenum disulphide.

Refer to [GI-4, "Components"](#) for symbols not described on the above.

Removal and Installation

INFOID:000000005630977

CAUTION:

Keep painted surface on the body or other parts free of clutch fluid. If it spills, wipe up immediately and wash the affected area with water.

REMOVAL

1. Drain clutch fluid. Refer to [CL-7, "Draining"](#).
2. Remove brake master cylinder cover. Refer to [EXT-21, "Removal and Installation"](#).
3. Remove brake booster pressure sensor. Refer to [BR-35, "Removal and Installation"](#).

CLUTCH MASTER CYLINDER

< REMOVAL AND INSTALLATION >

4. Remove mounting bolts (↔) and then remove reservoir tank assembly from the vehicle.

↔ : Vehicle front

5. Remove hose and clips from reservoir tank and master cylinder.
6. Remove reservoir tank mounting bolts and washers and then remove bracket from reservoir tank.
7. Remove ABS actuator and electric unit (control unit). Refer to [BRC-110, "Removal and Installation"](#).
8. Remove clutch tube from master cylinder, using a flare nut wrench.
9. Remove snap pin and clevis pin from clevis and then separate clevis from clutch pedal.
10. Remove master cylinder mounting nuts and then remove packing (1) and master cylinder assembly (2) from the vehicle.

↔ : Vehicle front

CAUTION:

Never damage packing, brake booster, and dash lower.

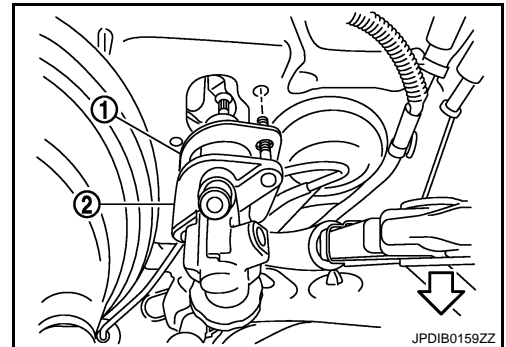
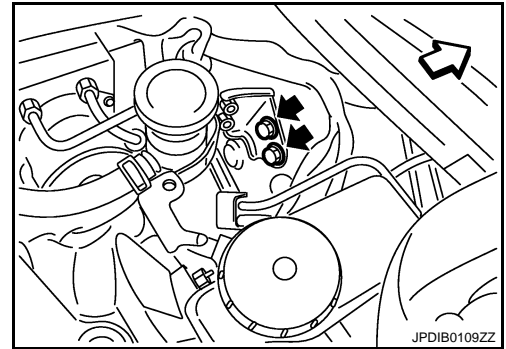

INSTALLATION

1. Install packing (1) and master cylinder assembly (2) to the vehicle.

↔ : Vehicle front

CAUTION:

• **Never damage packing, brake booster, and dash lower.**

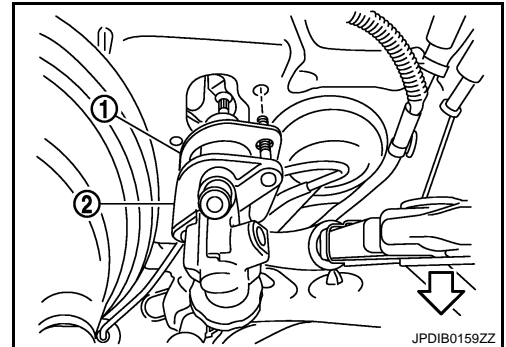

• **Be careful with the orientation of packing. The figure is the view from the vehicle forward.**

2. Tighten master cylinder mounting nuts to the specified torque.
3. Connect clutch tube to master cylinder and then temporarily tighten clutch tube flare nut, using a flare nut wrench.
4. Set clevis to clutch pedal.
5. Apply recommended grease to clevis pin and then install clevis pin to clevis.
6. Install snap pin to clevis pin.
7. Tighten clutch tube flare nut to the specified torque, using a flare nut torque wrench [Commercial service tool]. Refer to [CL-15, "Exploded View"](#).

CAUTION:

Never damage flare nut and clutch tube.

8. Install ABS actuator and electric unit (control unit). Refer to [BRC-110, "Removal and Installation"](#).
9. Install washers to reservoir tank mounting bolts.
10. Install bracket to reservoir tank and then tighten reservoir tank mounting bolts to the specified torque.

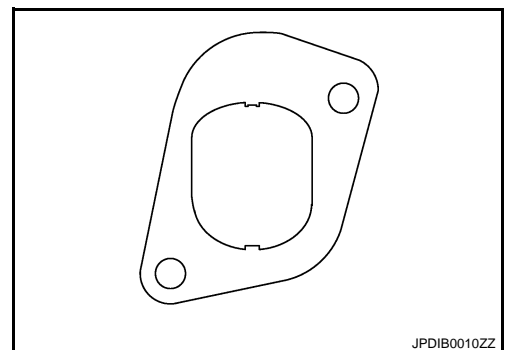

CLUTCH MASTER CYLINDER

< REMOVAL AND INSTALLATION >

11. Install hose (1) and clips to reservoir tank (2) and master cylinder (3).

← : Painted mark

CAUTION:
Set hose with painted mark facing upward.

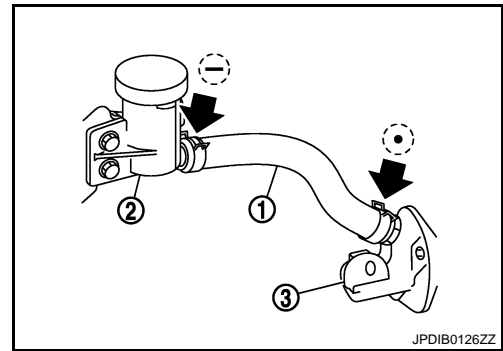

12. Install reservoir tank assembly to the vehicle and then tighten mounting bolts (↔) to the specified torque.

↔ : Vehicle front

13. Install brake booster pressure sensor. Refer to [BR-35, "Removal and Installation"](#).
14. Install brake master cylinder cover. Refer to [EXT-21, "Removal and Installation"](#).
15. Fill with clutch fluid. Refer to [CL-7, "Refilling"](#).

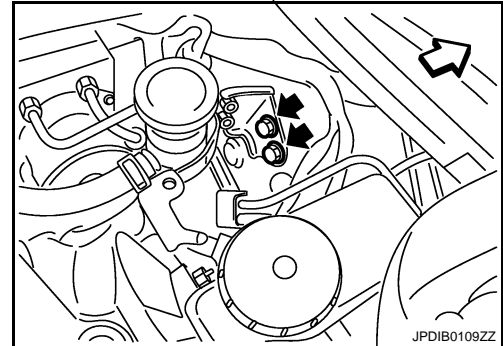

Disassembly and Assembly

INFOID:000000005630978

DISASSEMBLY

1. Remove clevis and push rod lock nut from push rod.
2. Remove boot from master cylinder.
3. Remove stopper ring from master cylinder while holding push rod.
4. Remove push rod, piston, and return spring from master cylinder.

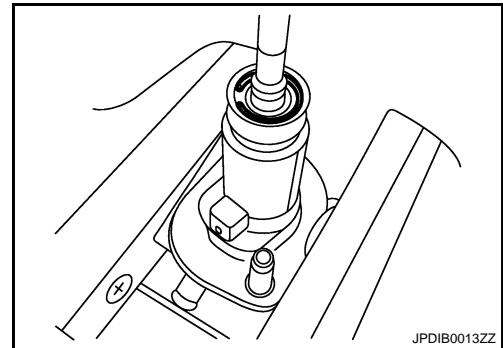

ASSEMBLY

1. Apply rubber lubricant to the internal surface of master cylinder, the sliding surface and piston cup of piston.
2. Install return spring and piston to master cylinder.
3. Apply silicon grease to push rod.
4. Install push rod to master cylinder.
5. Install stopper ring to master cylinder while holding push rod.
CAUTION:
Never reuse stopper ring.
6. Install boot to master cylinder.
7. Install push rod lock nut and clevis to push rod.

A
B
C
CL
E
F
G
H
I
J
K
L
M
N
O
P

CLUTCH MASTER CYLINDER

< REMOVAL AND INSTALLATION >

- Adjust the length "L" between clevis (1) and master cylinder (2) to the standard value.

Length "L" between clevis and master cylinder : Refer to [CL-24, "Clutch Master Cylinder"](#).

NOTE:

Clutch pedal height is controlled with position of clevis and master cylinder.

- Tighten push rod lock nut (3) to the specified torque.

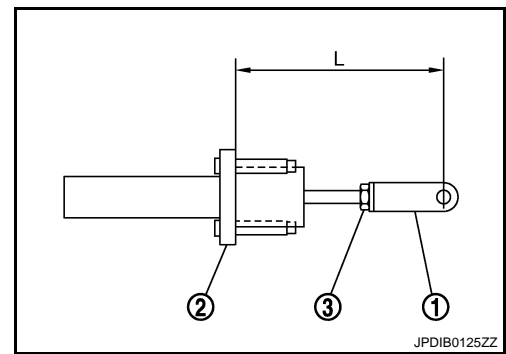

INFOID:000000005630979

Inspection and Adjustment

INSPECTION AFTER DISASSEMBLY

Check for any of the conditions shown below. If any malfunction is found, replace the part concerned.

- Damaged cylinder internal wall, foreign matter, wear, corrosion, or pinhole.
- Damaged or deformed reservoir tank.
- Settling of return spring.
- Cracked or deformed boot.
- Cracked or deformed packing.

ADJUSTMENT BEFORE INSTALLATION

- Check the length "L" between clevis (1) and master cylinder (2).

Length "L" between clevis and master cylinder : Refer to [CL-24, "Clutch Master Cylinder"](#).

- If measurement is outside the standard value, adjust the length "L" between clevis and master cylinder to the standard value.
- Tighten push rod lock nut (3) to the specified torque.

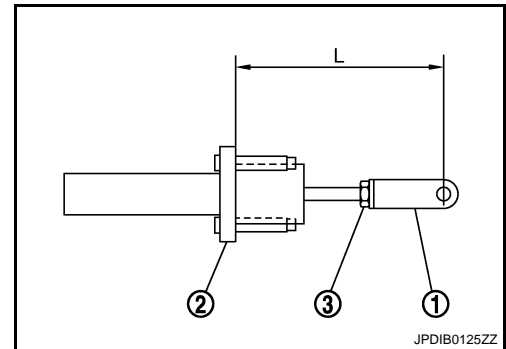

INSPECTION AFTER INSTALLATION

- Check the fluid leakage and the fluid level. Refer to [CL-7, "Inspection"](#).
- Check the clutch pedal free play. Refer to [CL-6, "Inspection and Adjustment"](#).

ADJUSTMENT AFTER INSTALLATION

- Adjust the clutch interlock switch position. Refer to [CL-6, "Inspection and Adjustment"](#).
- Perform the air bleeding. Refer to [CL-7, "Air Bleeding Procedure"](#).

CLUTCH PIPING

< REMOVAL AND INSTALLATION >

CLUTCH PIPING

Exploded View

INFOID:000000005630980

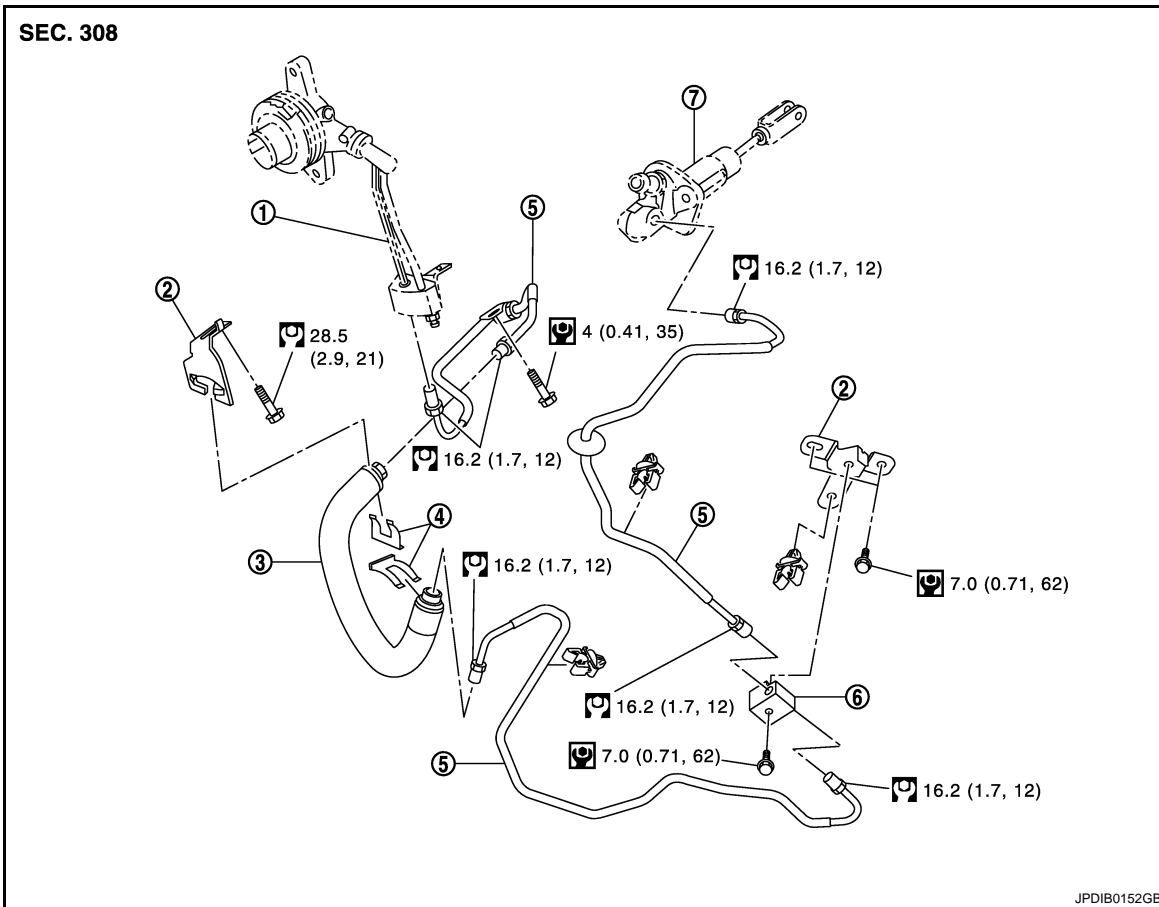

- | | | |
|---|----------------|----------------|
| 1. CSC (Concentric Slave Cylinder) assembly | 2. Bracket | 3. Clutch hose |
| 4. Lock plate | 5. Clutch tube | 6. Connector |
| 7. Master cylinder assembly | | |

Refer to [GI-4, "Components"](#) for the symbols in the figure.

Hydraulic Layout

INFOID:000000005630981

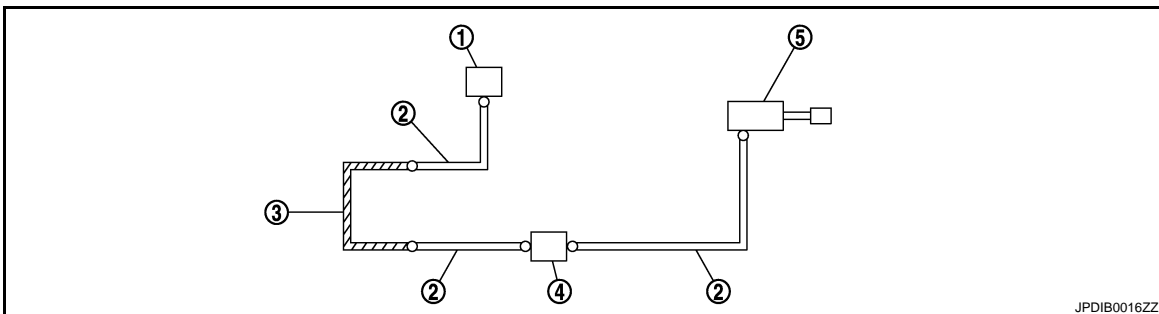

- | | | |
|---|-----------------------------|----------------|
| 1. CSC (Concentric Slave Cylinder) assembly | 2. Clutch tube | 3. Clutch hose |
| 4. Connector | 5. Master cylinder assembly | |

CLUTCH PIPING

< REMOVAL AND INSTALLATION >

Removal and Installation

INFOID:000000005630982

CAUTION:

Keep painted surface on the body or other parts free of clutch fluid. If it spills, wipe up immediately and wash the affected area with water.

REMOVAL

Note the following, and refer to [CL-15, "Exploded View"](#) for removal procedure.

- Drain clutch fluid. Refer to [CL-7, "Draining"](#).
- Remove clutch tube, using a flare nut wrench.

CAUTION:

Never damage flare nut and clutch tube.

INSTALLATION

Note the following, and refer to [CL-15, "Exploded View"](#) for installation procedure.

- To fix clutch hose on bracket, position clutch hose clasp on the emboss of bracket and drive lock plate vertically from above.

CAUTION:

- Never bend or twist clutch hose.
- Never scratch or damage clutch hose.
- Tighten clutch tube flare nut to the specified torque, using a flare nut torque wrench [Commercial service tool].

CAUTION:

Never damage flare nut and clutch tube.

- Fill with clutch fluid. Refer to [CL-7, "Refilling"](#).

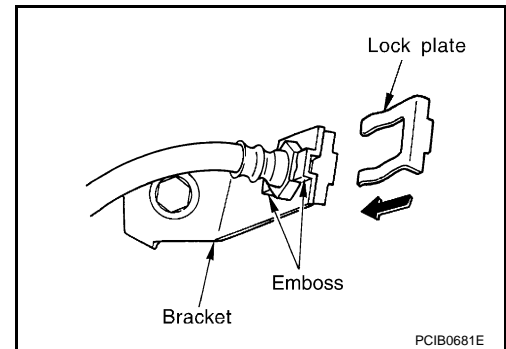

Inspection and Adjustment

INFOID:000000005630983

INSPECTION AFTER INSTALLATION

Check the fluid leakage and the fluid level. Refer to [CL-7, "Inspection"](#).

ADJUSTMENT AFTER INSTALLATION

Perform the air bleeding. Refer to [CL-7, "Air Bleeding Procedure"](#).

CSC (CONCENTRIC SLAVE CYLINDER)

< UNIT REMOVAL AND INSTALLATION >

UNIT REMOVAL AND INSTALLATION

CSC (CONCENTRIC SLAVE CYLINDER)

Exploded View

INFOID:000000005630984

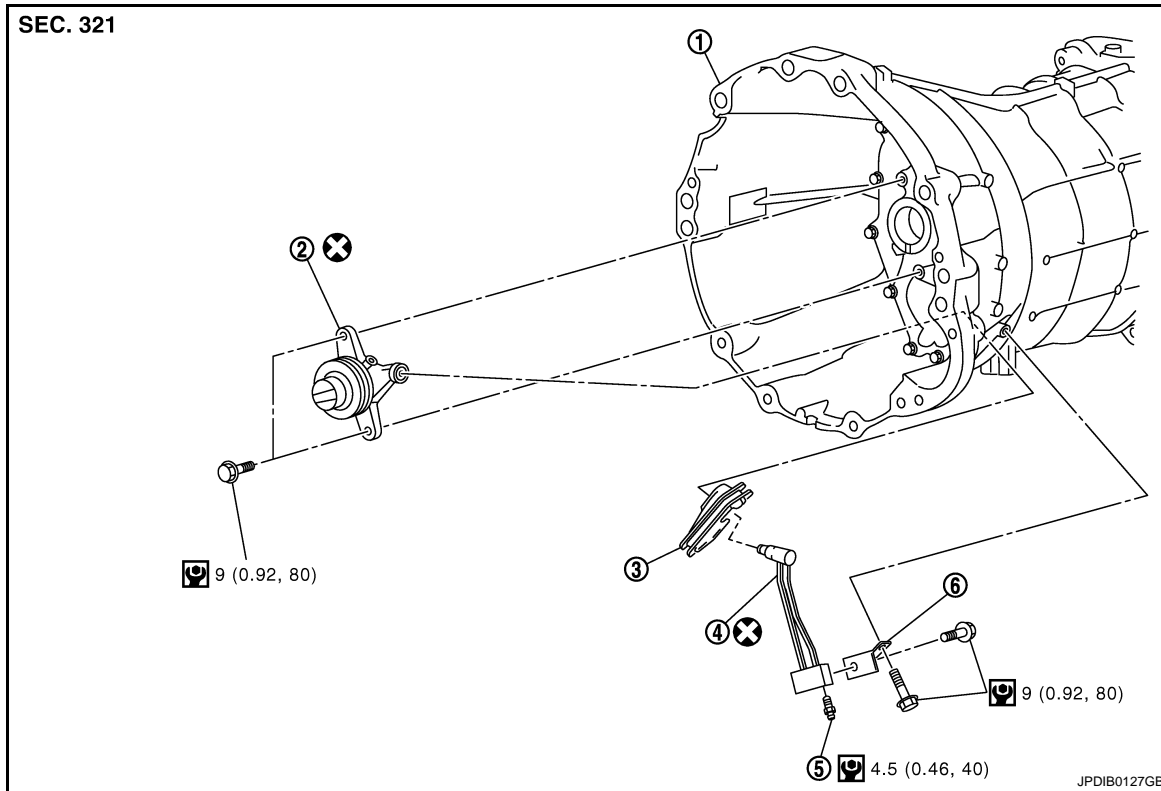

- | | | |
|---|---|---------------|
| 1. Transmission assembly | 2. CSC (Concentric Slave Cylinder) body | 3. Dust cover |
| 4. CSC (Concentric Slave Cylinder) tube | 5. Air bleeder valve | 6. Bracket |

Refer to [GI-4, "Components"](#) for the symbols in the figure.

Removal and Installation

INFOID:000000005630985

CAUTION:

- Never reuse CSC (Concentric Slave Cylinder) body and CSC tube. Because CSC slides back to the original position every time when removing transmission assembly. At this timing, dust on the sliding parts may damage a seal of CSC and may cause clutch fluid leakage.
- Never disassemble CSC body.
- Keep painted surface on the body or other parts free of clutch fluid. If it spills, wipe up immediately and wash the affected area with water.

REMOVAL

1. Remove transmission assembly from the engine. Refer to [TM-33, "Removal and Installation"](#).

CSC (CONCENTRIC SLAVE CYLINDER)

< UNIT REMOVAL AND INSTALLATION >

2. Remove mounting bolt (←).

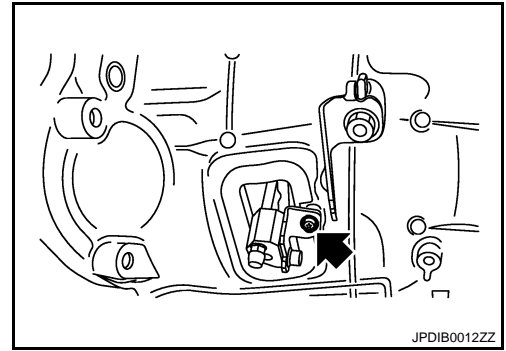

3. Pull up the lock pin of the CSC body.

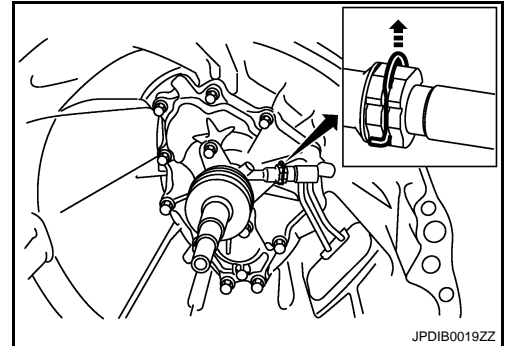

4. Pull out the CSC tube (1) from the CSC body (2).
5. Remove CSC tube and dust cover from transmission case.
6. Remove air bleeder valve and bracket from CSC tube.

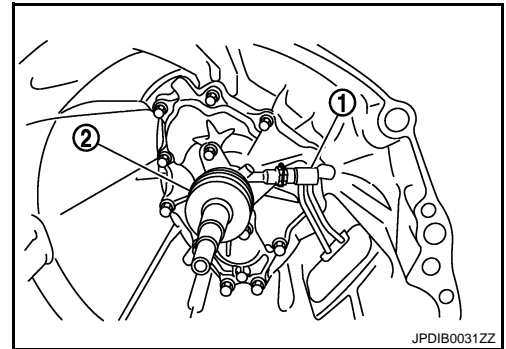

7. Remove CSC body from transmission case.

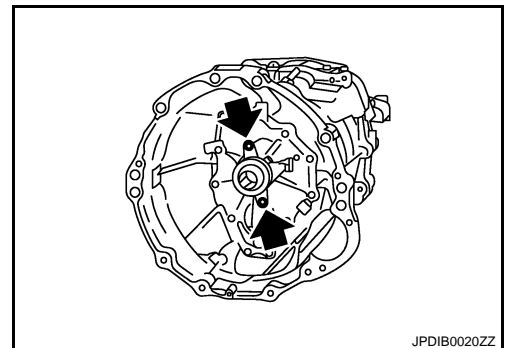

INSTALLATION

CSC (CONCENTRIC SLAVE CYLINDER)

< UNIT REMOVAL AND INSTALLATION >

1. Install CSC body to transmission case and then tighten mounting bolts (↔) to the specified torque.

CAUTION:

- Never reuse CSC body.
- Never insert and operate CSC body because piston and stopper of CSC body components may fall off.

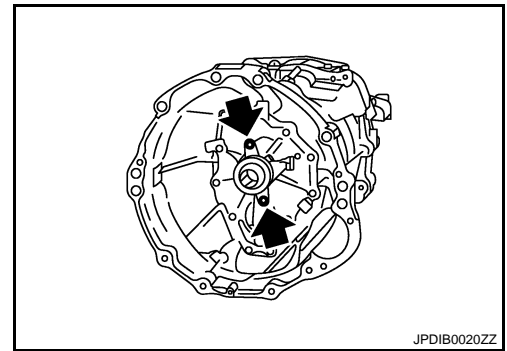

2. Install dust cover to transmission case.

↔ : Vehicle front

CAUTION:

Be careful with the orientation of dust cover.

3. Insert CSC tube to dust cover.

CAUTION:

- Never reuse CSC tube.
- Never damage O-ring of CSC tube.

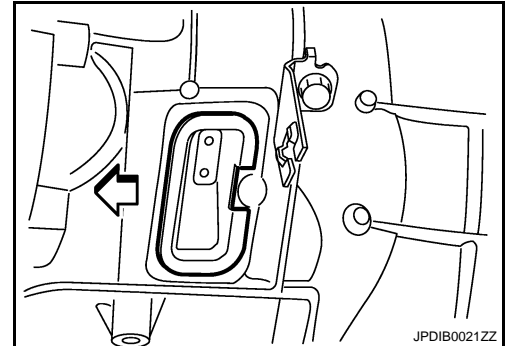

4. Press down the lock pin of the CSC body.

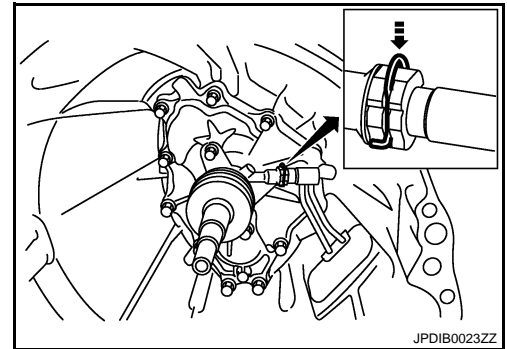

5. Insert the CSC tube (1) into the connector of the CSC body (2) until it clicks.

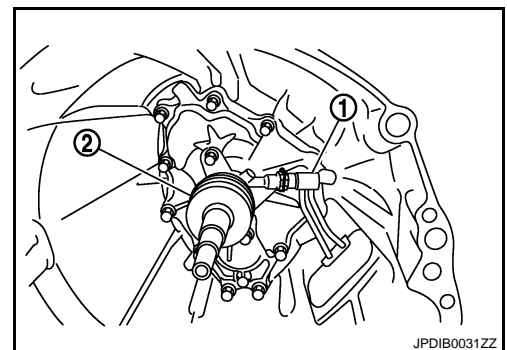

6. Install bracket and mounting bolts (↔) and then tighten mounting bolts to the specified torque in the numerical order as shown in the figure.

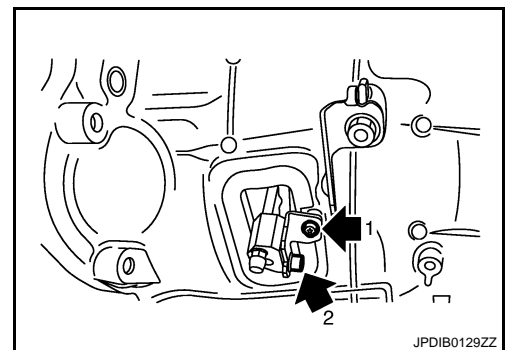

A
B
C
CL
E
F
G
H
I
J
K
L
M
N
O
P

CSC (CONCENTRIC SLAVE CYLINDER)

< UNIT REMOVAL AND INSTALLATION >

CAUTION:

- Check that CSC tube's (B) and bracket (1) are fit tightly before tightening the mounting bolt (A).
 - Tighten the mounting bolt within the range of bracket's mounting hole.
 - After replacing the CSC tube, the mounting bolt (C) is still temporary tightening. Never forget tightening the mounting bolt.
7. Install air bleeder valve to CSC tube and then tighten air bleeder valve to the specified torque.
 8. Install transmission assembly to the engine. Refer to [TM-33. "Removal and Installation"](#).

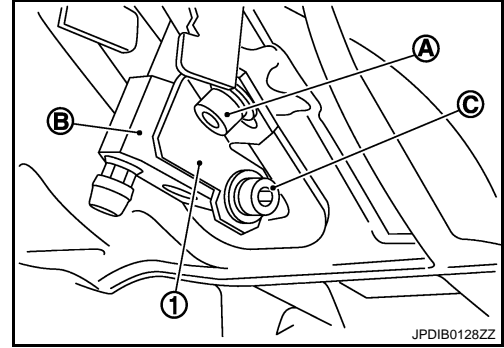

INFOID:000000005630986

Inspection and Adjustment

INSPECTION AFTER INSTALLATION

Check the fluid leakage and the fluid level. Refer to [CL-7. "Inspection"](#).

ADJUSTMENT AFTER INSTALLATION

Perform the air bleeding. Refer to [CL-7. "Air Bleeding Procedure"](#).

CLUTCH DISC AND CLUTCH COVER

< UNIT REMOVAL AND INSTALLATION >

CLUTCH DISC AND CLUTCH COVER

Exploded View

INFOID:000000005630987

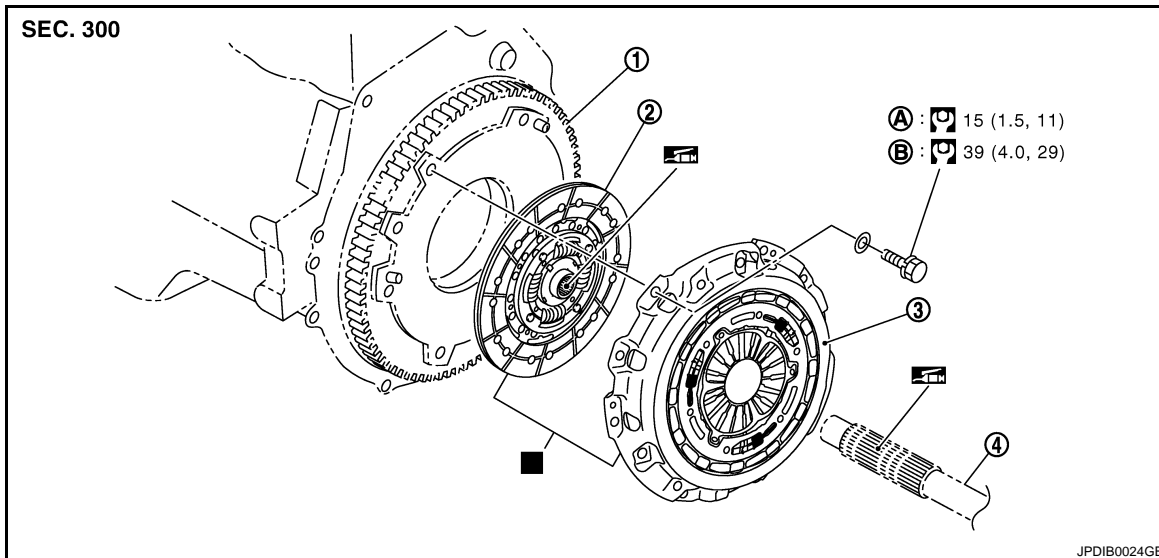

- 1. Flywheel
- 2. Clutch disc
- 3. Clutch cover
- 4. Main drive gear
- A. First step
- B. Final step

■ : Replace the parts as a set.

☑ : Apply lithium-based grease including molybdenum disulphide.

Refer to [GI-4, "Components"](#) for symbols not described on the above.

Removal and Installation

INFOID:000000005630988

CAUTION:

- Never reuse CSC (Concentric Slave Cylinder) body and CSC tube. Because CSC slides back to the original position every time when removing transmission assembly. At this timing, dust on the sliding parts may damage a seal of CSC and may cause clutch fluid leakage. Refer to [CL-17, "Removal and Installation"](#).

- Never bring any grease to the clutch disc facing, pressure plate surface and flywheel surface.
- Never clean clutch disc using solvent.

If flywheel is removed, align dowel pin with the smallest hole of flywheel. Refer to [EM-112, "Disassembly and Assembly"](#).

REMOVAL

1. Remove transmission assembly from the engine. Refer to [TM-33, "Removal and Installation"](#).
2. Remove clutch cover mounting bolts and washers while holding clutch cover, using a power tool [Commercial service tool].

CAUTION:

Never drop clutch disc.

3. Remove clutch cover and clutch disc.

CAUTION:

Never drop clutch disc.

INSTALLATION

1. Clean clutch disc and main drive gear splines to remove grease and powder arisen from abrasion.
2. Apply recommended grease to clutch disc and main drive gear splines.

CAUTION:

Be sure to apply grease to the points specified. Otherwise, noise, poor disengagement, or damage to the clutch may result. Excessive grease may cause slip or judder. And if it adheres to seal of

CLUTCH DISC AND CLUTCH COVER

< UNIT REMOVAL AND INSTALLATION >

CSC body, it cause clutch fluid leakage. Wipe out excess grease. Wipe out any grease oozing from the parts.

3. Install clutch disc, using a clutch aligner [Commercial service tool].

CAUTION:

If either clutch disc or clutch cover is needed to be replaced, replace them as a set.

4. Install washers to clutch cover mounting bolts.
5. Install clutch cover and then temporarily tighten clutch cover mounting bolts.

CAUTION:

If either clutch disc or clutch cover is needed to be replaced, replace them as a set.

6. Tighten clutch cover mounting bolts to the specified torque evenly in two steps in the numerical order as shown in the figure.
7. Install transmission assembly to the engine. Refer to [TM-33. "Removal and Installation"](#).

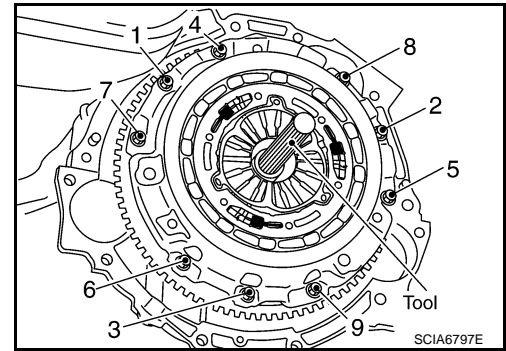

Inspection

INFOID:000000005630989

INSPECTION AFTER REMOVAL

CLUTCH DISC

- Measure circumferential runout relative to clutch disc center spline. If it is outside the specification, replace clutch disc and clutch cover as a set.

Runout limit/diameter of the area to be measured : Refer to [CL-24. "Clutch Disc"](#).

- Measure backlash to clutch disc spline and main drive gear spline at the circumference of clutch disc. If it is outside the specification, replace clutch disc and clutch cover as a set.

Maximum allowable spline backlash (at outer edge of disc) : Refer to [CL-24. "Clutch Disc"](#).

- Measure the depth "A" to clutch disc facing rivet heads, using a calipers. If it exceeds the allowable wear limit, replace clutch disc and clutch cover as a set.

Facing wear limit (depth to the rivet head) "A" : Refer to [CL-24. "Clutch Disc"](#).

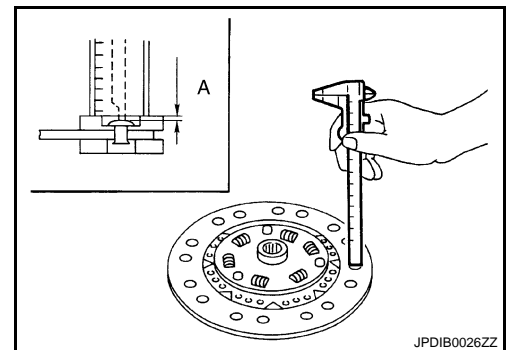
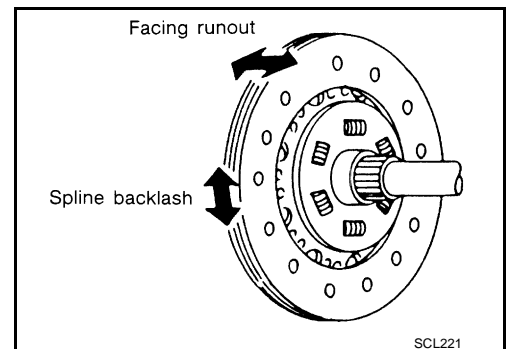

CLUTCH COVER

- Check clutch cover thrust ring for wear or breakage. If wear or breakage is found, replace clutch disc and clutch cover as a set.

NOTE:

- Worn thrust ring will generate a beating noise when tapped at the rivet with a hammer.
- Broken thrust ring will make a clinking sound when cover is shaken up and down.
- If a trace of burn or discoloration is found on the clutch cover pressure plate to clutch disc contact surface, repair the surface with sandpaper. If surface is damaged or distorted, replace clutch disc and clutch cover as a set.

INSPECTION AFTER INSTALLATION

CLUTCH COVER

CLUTCH DISC AND CLUTCH COVER

< UNIT REMOVAL AND INSTALLATION >

Check diaphragm spring lever claws for unevenness with the lever still on the vehicle. If they exceed the tolerance, adjust lever height, using the diaphragm adjusting wrench (A) [SST: ST20050240 (-)].

Tolerance for diaphragm spring lever unevenness : Refer to [CL-24, "Clutch Cover"](#).

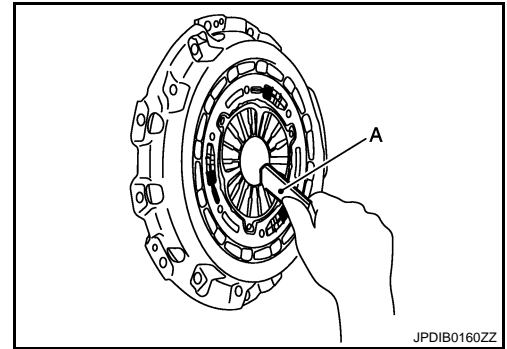

A
B
C

CL

E
F
G
H
I
J
K
L
M
N
O
P

SERVICE DATA AND SPECIFICATIONS (SDS)

< SERVICE DATA AND SPECIFICATIONS (SDS)

SERVICE DATA AND SPECIFICATIONS (SDS)

SERVICE DATA AND SPECIFICATIONS (SDS)

Clutch Control System

INFOID:000000005630990

| | |
|------------------------|-----------|
| Type of clutch control | Hydraulic |
|------------------------|-----------|

Clutch Pedal

INFOID:000000005630991

Unit: mm (in)

| | |
|--|---------------------------|
| Clearance "C" between pedal stopper rubber and clutch interlock switch threaded while clutch pedal is fully depressed. | 0.1 – 1.0 (0.004 – 0.039) |
|--|---------------------------|

Clutch Master Cylinder

INFOID:000000005630992

Unit: mm (in)

| | |
|---|-----------------------------|
| Cylinder inner diameter | 17.46 (11/16) |
| Length "L" between clevis and master cylinder | 133.55 ± 0.5 (5.26 ± 0.020) |

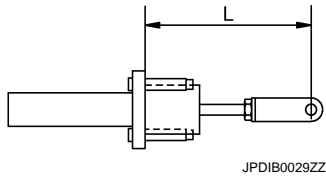

Clutch Disc

INFOID:000000005630993

Unit: mm (in)

| | |
|---|---------------------------------------|
| Facing size (Outer dia. × Inner dia. × Thickness) | 240 × 160 × 3.8 (9.45 × 6.30 × 0.150) |
| Runout limit/diameter of the area to be measured | 1.0 (0.039) / 230 (9.06) dia. |
| Maximum allowable spline backlash (at outer edge of disc) | 1.0 (0.039) |
| Facing wear limit (depth to the rivet head) "A" | 0.3 (0.012) |

Clutch Cover

INFOID:000000005630994

| | |
|---|---------------------------|
| Tolerance for diaphragm spring lever unevenness | 0.8 mm (0.031 in) or less |
|---|---------------------------|